

INTERLOCK 5 Range

Interlock 5 features

- The most versatile locking device available
- Designed to meet stringent International Standards
- Unique locking mechanism
- Easy to use – ultra reliable in use
- Removable for re-use or for inspection purposes
- Meets I.B.M specification
- Available for different board grades

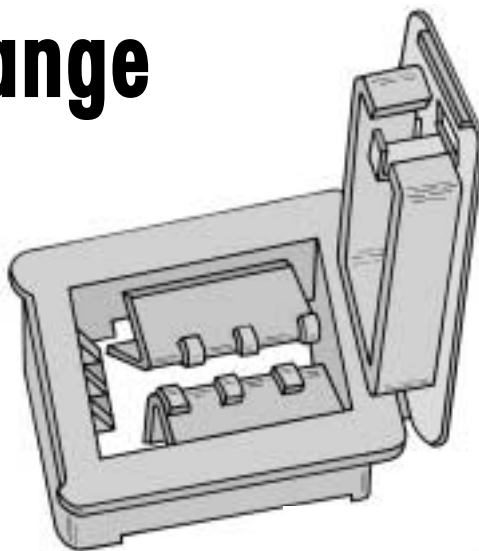

● Interlock 5 3D view open



● Interlock 5 3D view closed

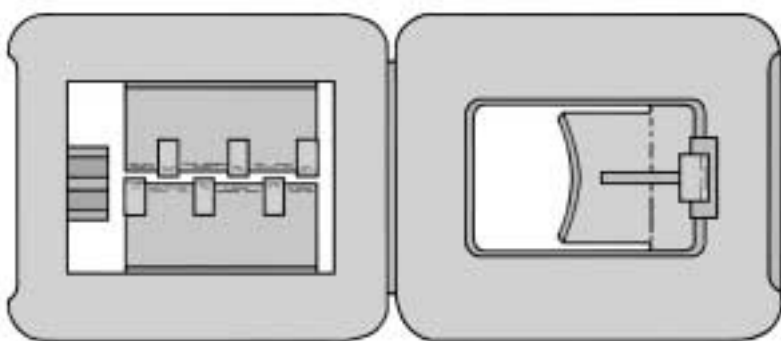

● Interlock 5 top view open

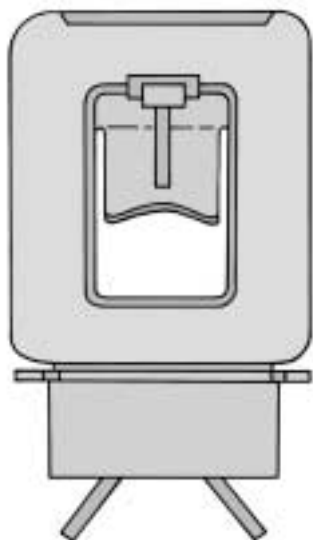
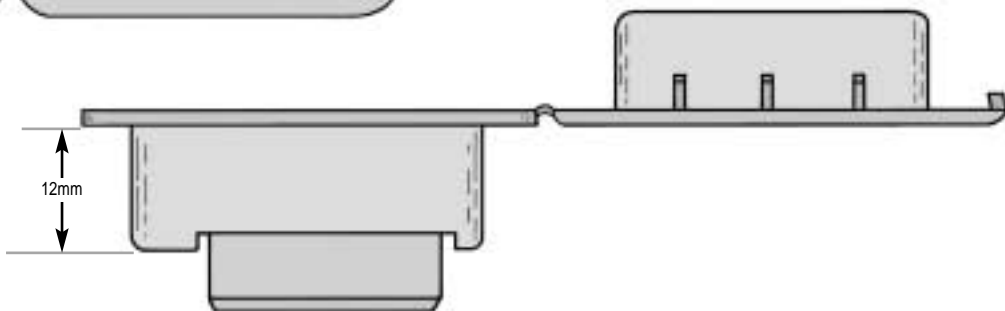

● Interlock 5 front view fully open



● Interlock 5 front view closing

- Available for board grades of 15mm, 21mm & 25mm



● Interlock 5 front view locked

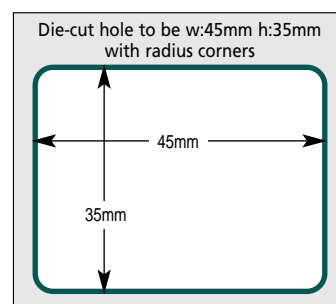

.....ANOTHER INNOVATIVE ITEM PRODUCT

For more information please contact

ITEM PRODUCTS (NPD) LIMITED

101 PARK STREET, LUTON, BEDS LU1 3HG

Tel: 01582 391 898 Fax: 01582 391 998 email: info@item-products.co.uk Web Site: www.item-products.co.uk